

**Untergeschoss**

	Hauptnutzfläche	0.0m <sup>2</sup>
	Nebennutzfläche	1505.0m <sup>2</sup>
	Verkehrsfläche	107.2m <sup>2</sup>
	Funktionsfläche	32.7m <sup>2</sup>

**Erdgeschoss**

	Hauptnutzfläche	308.6m <sup>2</sup>
	Nebennutzfläche	14.1m <sup>2</sup>
	Verkehrsfläche	147.0m <sup>2</sup>
	Funktionsfläche	1.8m <sup>2</sup>

**Obergeschoss**

	Hauptnutzfläche	25.4m <sup>2</sup>
	Nebennutzfläche	0.0m <sup>2</sup>
	Verkehrsfläche	7.7m <sup>2</sup>
	Funktionsfläche	48.9m <sup>2</sup>

**Total**

	Hauptnutzfläche	334.0m <sup>2</sup>
	Nebennutzfläche	1519.1m <sup>2</sup>
	Verkehrsfläche	261.9m <sup>2</sup>
	Funktionsfläche	83.4m <sup>2</sup>

2198.4m<sup>2</sup>

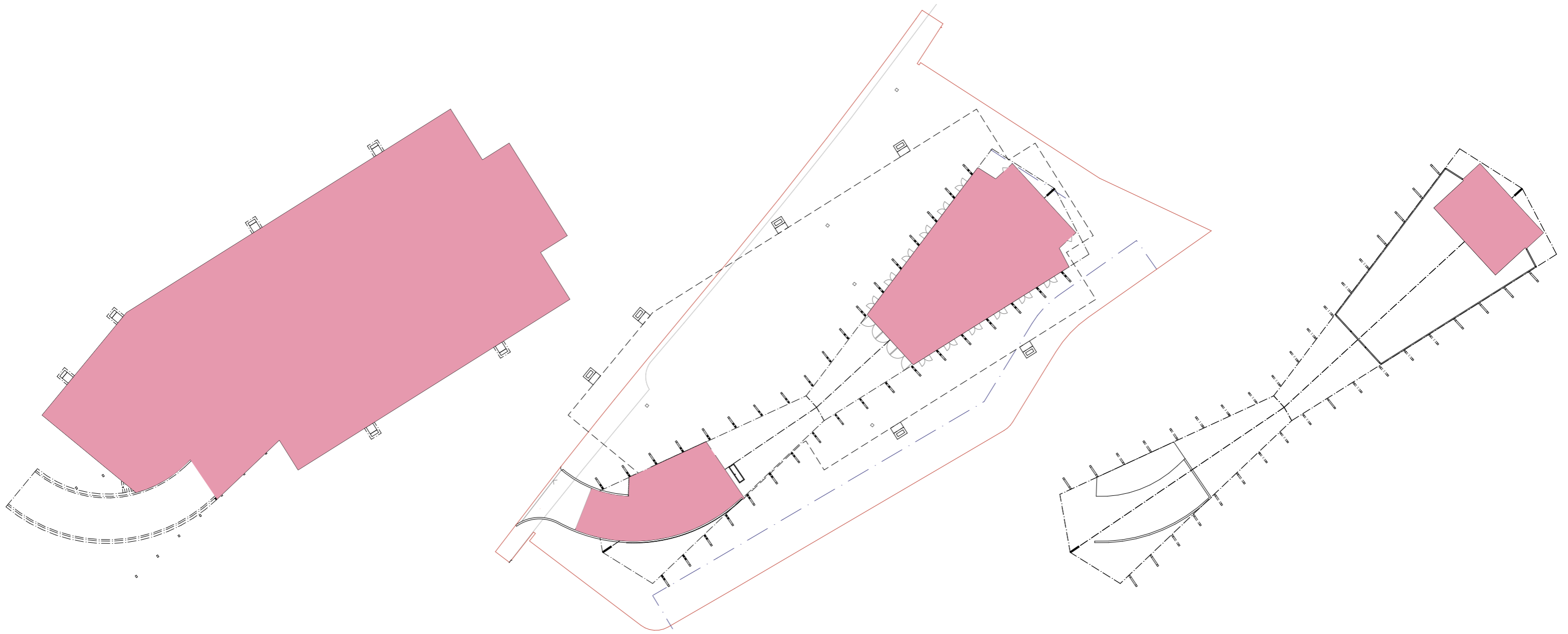





**Untergeschoss**  
 Geschossfläche 1709.0m<sup>2</sup>

**Erdgeschoss**  
 Geschossfläche 503.4m<sup>2</sup>

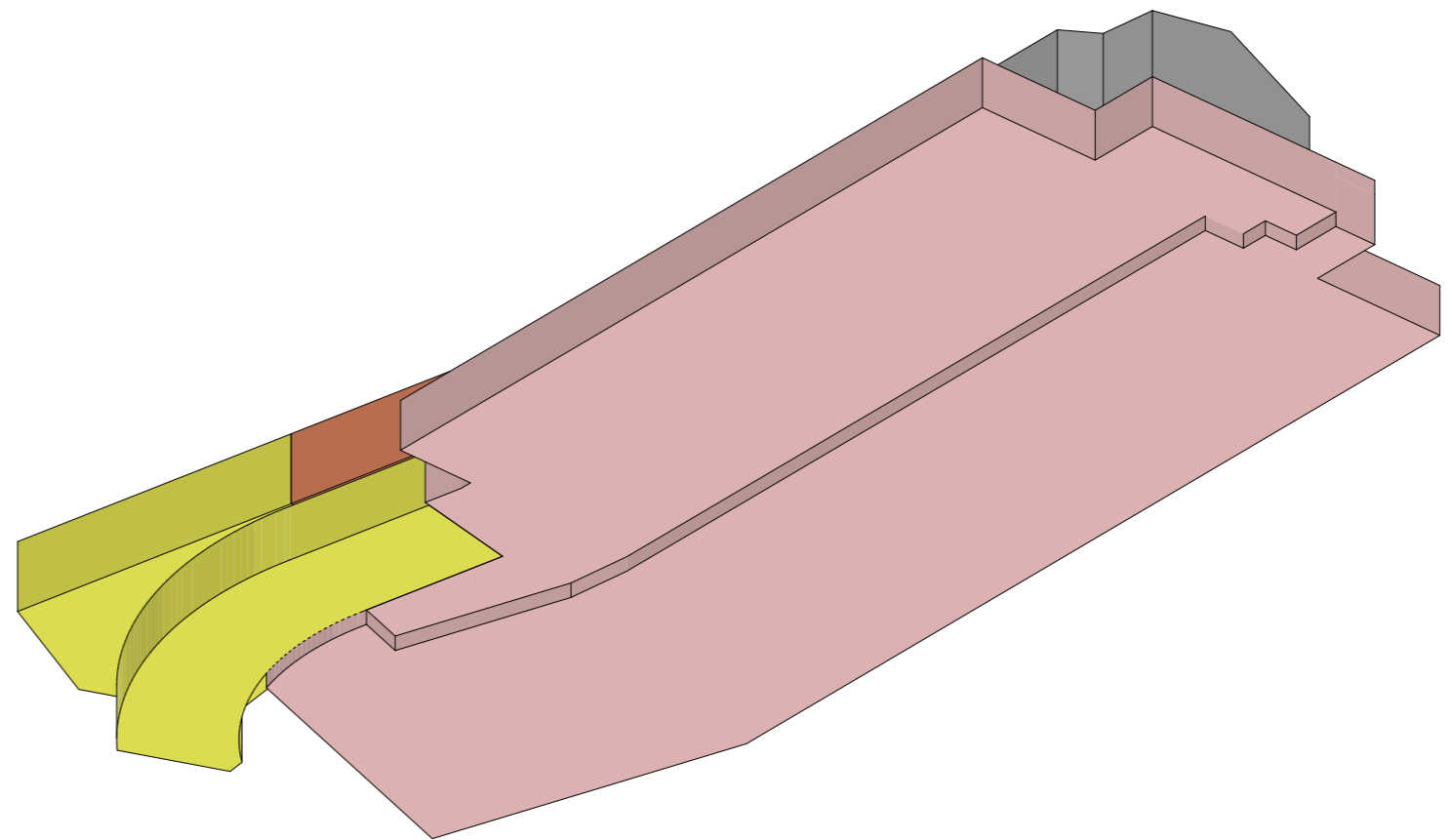
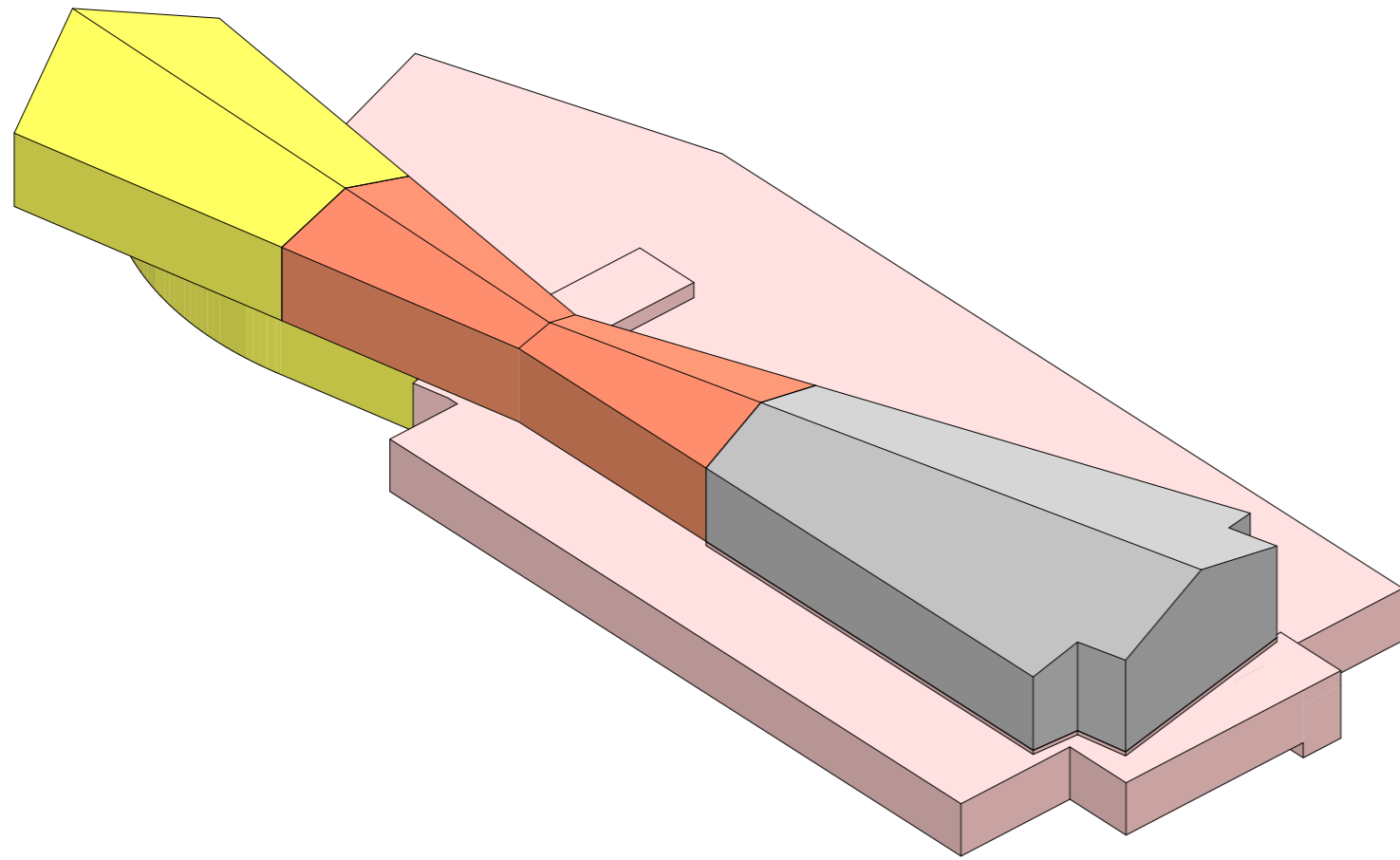
**Obergeschoss**  
 Geschossfläche 96.7m<sup>2</sup>

**Total**  
 Geschossfläche 2309.1m<sup>2</sup>



	Volumen UG	5398.6m <sup>2</sup>
	Volumen Halle Warm	1927.5m <sup>2</sup>
	Volumen Halle kalt	828.7m <sup>2</sup>
	Volumen EG kalt	1327.7m <sup>2</sup>
		<hr/>
		9482.5m <sup>2</sup>
		<hr/> <hr/>